

TORINO

modello modèle model Modell modell	cm	cm	Hp	PTO	N.	N.	Optional N.	rpm	Ø	Ø	Ø	Ø	Kg.
Torino 140	135	165	50/65	540	4	32	64	1780	50	180	430	180	625
Torino 160	155	185	60/70	540	4	36	72	1780	50	180	430	180	650
Torino 180	175	215	65/80	540	4	40	80	1780	50	180	430	180	675
Torino 200	195	227	70/80	540	4	44	88	1780	50	180	430	180	710
Torino 220	215	245	80/90	540	4	48	96	1780	50	180	430	180	740

TORINO E

modello modèle model Modell modell	cm	cm	Hp	PTO	N.	N.	Optional N.	rpm	Ø	Ø	Ø	Ø	Kg.
Torino 160 E	155	210	60/70	540	4	36	72	1780	50	180	430	180	735
Torino 180 E	175	230	65/80	540	4	40	80	1780	50	180	430	180	775
Torino 200 E	195	250	70/80	540	4	44	88	1780	50	180	430	180	845
Torino 220 E	215	270	80/90	540	4	48	96	1780	50	180	430	180	885
Torino 240 E	235	290	100/120	540	5	52	104	1780	50	180	430	180	1050
Torino 260 E	255	310	110/120	540	5	56	112	1780	50	180	430	180	1100

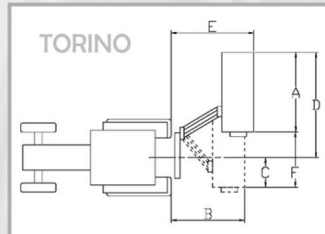
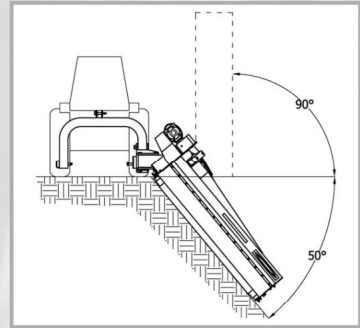

A	B	C	D	E	F
140	195	80	195	223	135
160	195	80	215	223	135
180	195	80	235	223	135
200	195	80	255	223	135
220	195	80	275	223	135

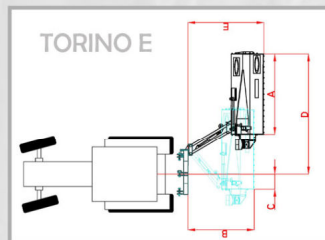

A	B	C	D	E	F
160	225	30	292	220	162
180	225	30	312	220	162
200	225	30	332	220	162
220	225	30	352	220	162
240	225	30	372	220	162
260	225	30	392	220	162

Torino

Tutte le macchine OMARV sono equipaggiate con i ripari antinfortunistici previsti dalla normativa CE e sono accompagnate del Certificato di Conformità CE.
Toutes les machines OMARV sont dotées des protections contre les accidents prévues par la réglementation CE et du Certificat de Conformité CE.
Alle OMARV Geräte sind serienmäßig mit Unfallschutzvorrichtungen gemäß EG-Richtlinien ausgerüstet und haben eine EG-Konformitätsbescheinigung (CE-Prüfzeichen).
All OMARV machines are equipped with protection devices according to EC regulation and provided with EC Certificate of Conformity.
Todas las máquinas OMARV están dotadas de los dispositivos de seguridad previstos por la legislación comunitaria CE y del Certificado de conformidad CE.

OMARV



OMARV s.r.l.
Via Cuneo 60, 12038 Savigliano (CN) Italy
P.IVA C.F. 03244910042
Tel: +39 0172.715114 - Fax: +39 0172.780028
E-mail: info@omarv.com
www.omarv.com



Green Line



TORINO

Trincia laterale
Broyeur d'accotement
Swing arm flail mower
Seitlicher Mulcher
Trituradora lateral

OMARV

the Italian technology in the world

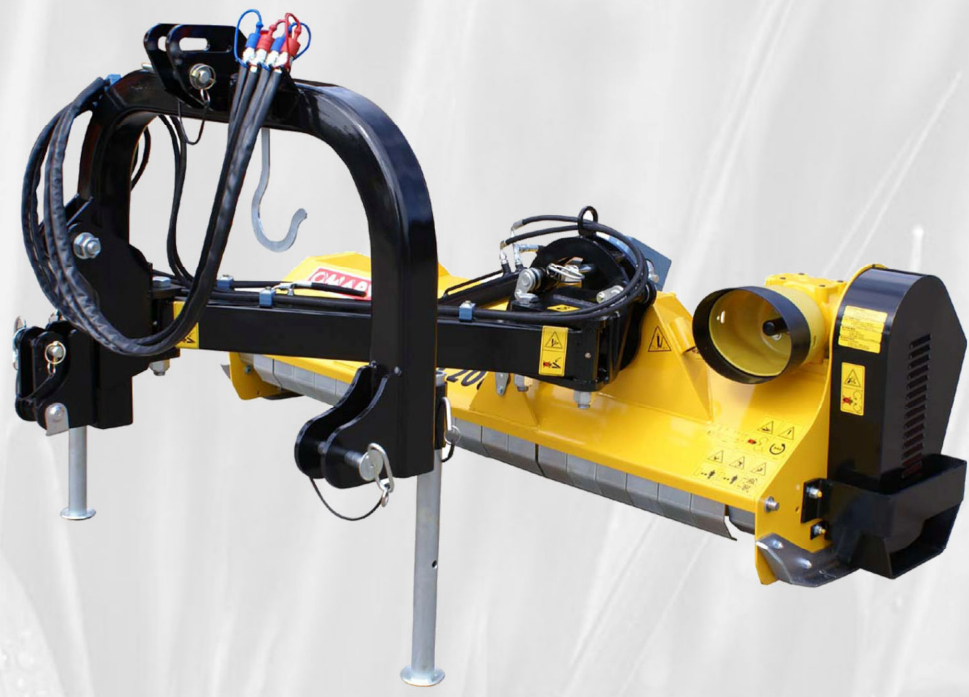

Versione con gruppo interno
Version avec boîtier à l'intérieur
Version with internal gearbox
Version mit inneren Getriebe
Versión con grupo de transmisión normal



Torino



Gruppo normale (interno)
Boîtier normal (à l'intérieur)
Normal gearbox (inside)
Normales Getriebe (inneren)
Grupo de transmisión normal

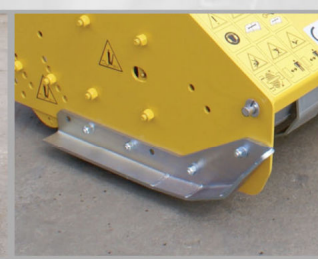

Slitte laterali regolabili
Patins laterales réglables
Adjustable side skids
Verstellbare seitliche Kufen
Patines laterales regulables



Doppia sicurezza meccanica
Double sécurité mécanique
Double mechanical safety
Doppelte mechanische Anfahrsicherheit
Doble seguridad mecánica



Ingrassaggio centralizzato e tendicinghia automatico
Graissage centralisé et tendeur de courroie automatique
Centralized greasing and automatic belt tightener
Zentralschmierung und automatischer Riemenpanner
Engrase centralizado y tensor de correa automático

THE ITALIAN TECHNOLOGY IN THE WORLD



Versione con gruppo esterno
Version avec boîtier à l'extérieur
Version with external gearbox
Version mit aussenliegenden Getriebe
Versión con grupo de transmisión exterior



Torino E



Gruppo esterno
Boîtier à l'extérieur
External gearbox
Externes Getriebe
Grupo de transmisión exterior



Coltelli a martello
Marteaux
Hammer blades
Hammerschaufeln
Martillos



Rullo regolabile
Rouleau réglable
Adjustable roller
Verstellbare Stützwalze
Rodillo regulable



Accumulatore oleopneumatico
Amortisseur oléopneumatique
Oleo-pneumatic shock absorber
Öl-Luft-Federbein
Acumulador neumático